

Attention ! The A-113 module requires an additional +5V power supply with 100mA (e.g. the separate +5V power supply or the +5V low-cost adapter)

1. Introduction

Module **A-113 (Subharmonic Generator)** is an additional sound source that derives four independent so-called **Subharmonics** from an incoming pulse signal. The module represents the sound generation core of the **Mixtur-Trautonium** introduced by **Oskar Sala** (ref. chapter 6).

Subharmonic means in this context a sawtooth wave whose frequency is derived from a master frequency. The master frequency is divided by an integer 1...24 to obtain the subharmonic. The subharmonics are available as **4 single outputs** as well as **mix output** with adjustable level for each subharmonic.

The integer **divisor** for each subharmonic is set with up/down buttons. The current divisors are displayed with four 2-digit LED displays.

The combination of 4 divisors is called **mixture**. 4 mixtures form a **preset**. 50 presets can be stored and called up within the module.

Two **gate inputs** are available to switch between the 4 mixtures within one preset (controlled by any gate signals, e.g. from foot controllers).

2. Basic principles

The Subharmonic Generator A-113 contains four times the following elements (see fig. 1)

- digital frequency divider (rectangle outputs) with 2-digit display and up/down buttons for divisor adjustment
- rectangle/sawtooth converter (with single output)
- attenuator controlling the amount (i.e. the amplitude) of the subharmonic in the mix output

The incoming signal (preferably the rectangle output of a VCO) is fed into the four frequency dividers. The frequencies of the rectangle signals generated by the frequency dividers are determined by the current divisors (1...24).

The rectangle outputs are converted to sawtooth waveforms by means of the rectangle/sawtooth converters.

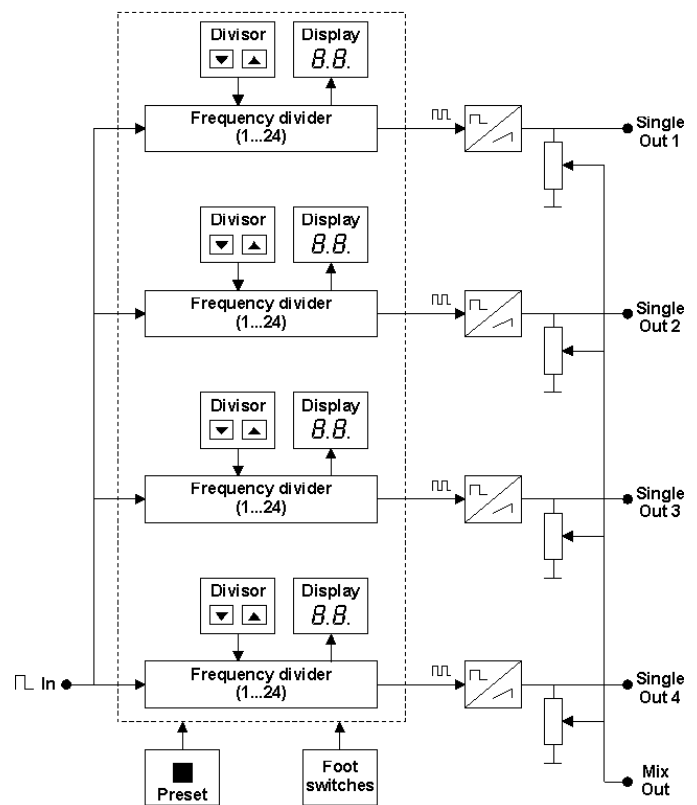

Fig. 1: Basic layout of the A-113

Subharmonics

The **subharmonics** result from **integer division of the frequency of the input signal**.

The table in fig. 2 shows the frequencies and corresponding tone pitches of the resulting subharmonics derived from an input signal with the tone pitch C⁵ (i.e. 523,2 Hz).

Divisor	Freq. [Hz]	Note
1	523,2	C ⁵
2	261,6	C ⁴
3	174,6	F ³
4	130,8	C ³
5	103,8	A ²
6	87,3	F ²
7	73,4	D ²
8	65,4	C ²



Fig. 2: Subharmonics of a signal with tone pitch C⁵

It becomes apparent that the subharmonics are equivalent to the tones of the **minor chord scale**.

By way of contrast the **harmonics** are equivalent to the tones of the **major chord scale**. Harmonics are integer multiples of the basic frequency (see fig. 3). The undertone series (i.e. subharmonics) are the mirror image of the overtone series (i.e. harmonics).

Factor	Freq. [Hz]	Note
1	65,4	C ²
2	130,8	C ³
3	196,0	G ³
4	261,6	C ⁴
5	329,6	E ⁴
6	392,0	G ⁴
7	466,1	B ⁴
8	523,2	C ⁵

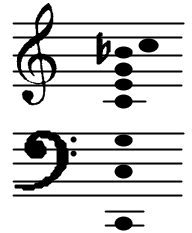

Fig. 3: Harmonics of a signal with tone pitch C²

H The term "subharmonic" is not quite correct as the A-113 outputs are sawtooth waveforms in contrast to the sine waves used in the harmonics theory. A sawtooth wave has a marked harmonic spectrum with odd and even overtones in contrast to the sine wave which is a "pure" wave without overtones. For details concerning harmonic contents of different waveforms please refer to the A-110 or A-111 manual (VCO's). We wanted to use the same terms as Oscar Sala in his *Mixtur Trautonium* and this is why we call the outputs of the A-113 *subharmonics* though they are sawtooth outputs.

Mixture

The combination of four subharmonics is called a **mixture**. **Four different mixtures** ("00", "01", "10" und "11") are available but only **one mixture** is **active** at a time. The original Mixtur-Trautonium had only three mixtures available but due to the binary structure of the A-113 we introduced 4 mixtures.

The active mixture is selected by the current state of the two **gate control inputs**. In the original Mixtur-Trautonium 2 foot switches mounted left and right of the

volume foot controller are used to switch between the 3 mixtures.

Preset

A **preset** consists of 4 mixtures with 4 divisors each (see fig. 4). 50 presets can be stored and called up within the A-113 module. The original Mixtur-Trautonium had no presets available. Each mixture had to be changed manually.

divisor (display)	T1	T1	T1	T1
	T2	T2	T2	T2
	T3	T3	T3	T3
	T4	T4	T4	T4
mixture	"00"	"01"	"10"	"11"

Fig. 4: Structure of a preset

2. Overview

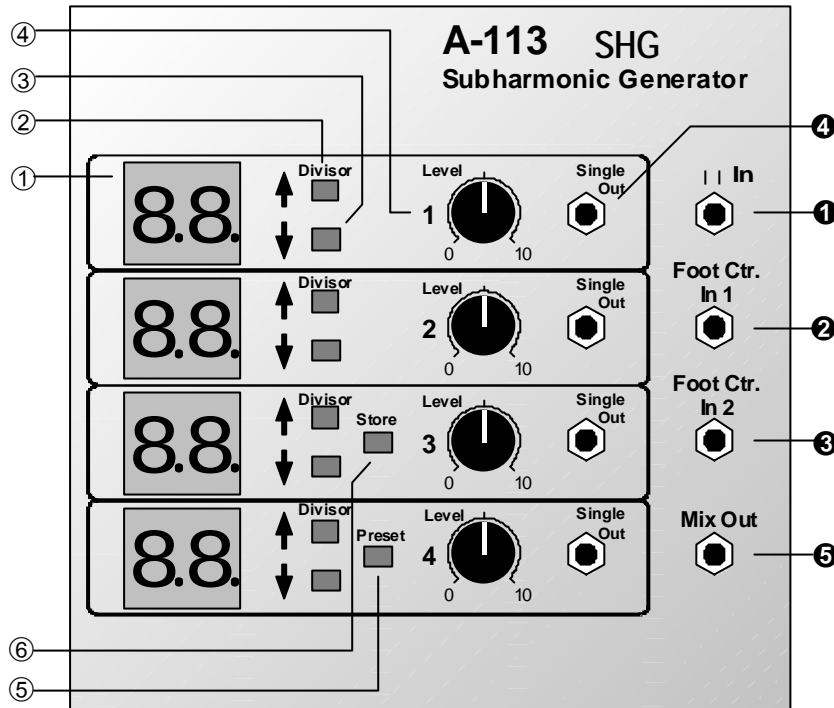

Controls:

- 1 Display : displays the current divisor
- 2 Up : button to increase the divisor data
- 3 Down : same to decrease
- 4 Level : output level control (mix output)
- 5 Preset : preset selection button
- 6 Store : preset store button

In / Outputs:

- ! In : common audio input (rectangle input)
- " Foot Ctr. 1 : gate input 1 to switch between the mixtures
- § Foot Ctr. 2 : gate input 2 to switch between the mixtures
- % Mix Out : audio mix output
- \$ Single Out : audio single output

3. Controls

1 Display

This is the 2-digit LED display that shows the **current value of the divisor**.

In addition the **decimal points** of the displays are used to display the **current mixture** (see fig. 5):

- **no** decimal point is on: **mixture "00"**
- **right** decimal points are on: **mixture "01"**
- **left** decimal points are on: **mixture "10"**
- **both** decimal points are on: **mixture "11"**

The mixture selected depends upon the states of the two gate inputs \$ und % (see chapter 4).

2 Up • 3 Down

The Up button 2 resp. the Down button 3 are used to adjust the **divisor** (range 01 to 24) for the corresponding frequency divider.

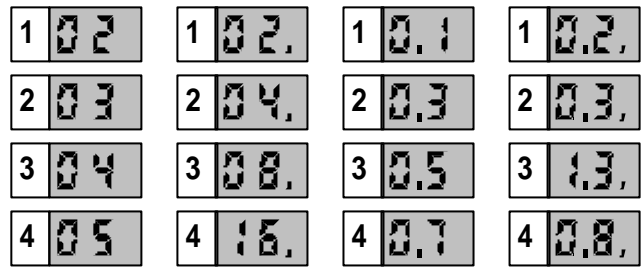

Fig. 5: Display of mixtures by means of decimal points (from left to right: "00", "01", "10", "11")

H Before you adjust the divisors be sure that you have selected the right mixture!

The **Up/Down** buttons of **frequency divider 4** are used for **preset selection** instead of divisor adjustment if the preset button 5 is operated simultaneously.

4 Level

The attenuators 4 control the **amount of the respective subharmonic** present at the mix output %.

5 Preset

While button 5 is operated one reaches the **preset mode** (see chapter 2 concerning the term *preset*). In this state the displays of the third and fourth frequency divider show "Pr" resp. the number of the preset currently selected (e.g. "45", see fig. 6a):

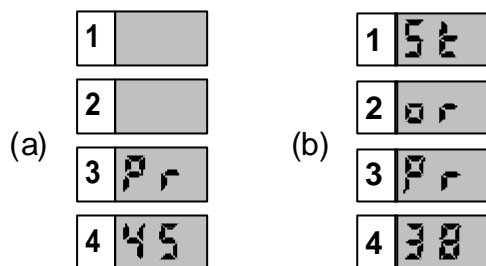

Fig. 6: (a): display of the current preset
(b): store preset with new preset number

To **select a new preset** the up/down buttons 2 and 3 of the fourth frequency divider are used while the preset button 5 is operated until the desired preset number appears in the fourth display.

As soon as the preset button 5 is released the module returns to the normal mode. The displays show the divisors of the new preset and the divisors can be adjusted with the corresponding up/down buttons.

6 Store

The store button 6 is used to **store presets**. The following steps are required to store a new preset:

- D Operate the preset button 5 and keep this button pressed down (see fig. 6a).
- D The up/down buttons 2 and 3 are used to select the preset number in which the current preset will be stored (preset button 5 remains operated).
- D Pressing the store button 6 (preset button 5 still remains operated) causes the storage of the current preset into the preset number selected. In the upper displays appears "St" and "or" as confirmation of the storage process (see fig. 6b).

H Pay attention not to select a preset number that already contains preset data you may need in the future. Any former preset data in the selected preset number are deleted!

As soon as both buttons preset 5 and store 6 are released the module returns to the normal mode. The displays show the divisors and the divisors can be adjusted with the corresponding up/down buttons.

4. In / Outputs

! In

Socket ! is the subharmonic generator's audio input. Connect up the signal you wish to use as master frequency signal (normally the rectangle output of a VCO).

" Foot Ctr. In 1 • § Foot Ctr. In 2

The gate inputs " and § are used to **select the mixture**. Any gate type signals may be used (e.g. Foot Controller, Sequencer gate outputs, MIDI interface) (see fig. 7).

Foot Ctr. In 1	Foot Ctr. In 2	Mixture	Display example
0	0	"00"	02
0	1	"01"	04.
1	0	"10"	0.1
1	1	"11"	13.

Fig. 7: Selecting mixtures with gate signals
(0: gate = low or no gate signal applied,
1: gate = high)

The mixture is displayed with the decimal points (see chapter 3, fig. 5).

\$ Single Out

Sockets " outputs the **single subharmonic** of the respective frequency divider. The attenuators 4 do not affect the level at these sockets.

% Mix Out

At output § the mix of the 4 subharmonics adjusted with the 4 attenuators 4 is available.

5. User Examples

Simulation of a Mixtur-Trautonium

The **Trautonium** is an electronic musical instrument invented by Friedrich Trautwein in the thirties in Berlin, Germany, with enhancements made by Oskar Sala in the fifties which led to the well known Mixtur-Trautonium. The Trautonium can be divided into two logical sub-units: the control unit and the sound generation unit.

A detailed description of the **Mixtur-Trautonium** and the realization with the A-100 modular system can be found on our web site www.doepfer.com.

The replica of the Trautonium sound generation with the A-100 presents itself as the A-113 contains all the basic sound source elements of the Trautonium. The Trautonium Format Filter A-104 completes the sound generation as it is a copy of the lowpass/bandpass arrangement of the Mixtur Trautonium. Only a few A-100 standard modules (VCO, VCA, LFO, ADSR) have to be added to obtain the typical Trautonium sound.

Fig. 8 shows the schematic construction of the Trautonium sound generation using A-100 modules.

A-113 as a complex sound source

A-113 in combination with a VCO makes available a very complex and powerful sound source for a lot of sound experiments. The four subharmonics generated by the A-113 contain strong harmonic spectra with even and odd harmonics. They represent ideal basic sound sources to be modified with separate sound processing modules.

Fig. 9 shows an example. "XYZ" represents any sound processing combination of modules: e.g. VCF, VCA, Phaser, Distortion, Ring Modulator, Vocoder, Frequency Shifter, Spring Reverb and so on with controlling modules like ADSR, LFO, Random, S&H, Theremin, Light-controlled CV, Joy Stick, MIDI interface and so on. The controlling modules may be triggered or synchronized (e.g. with a keyboard or sequencer controlled gate) or free running.

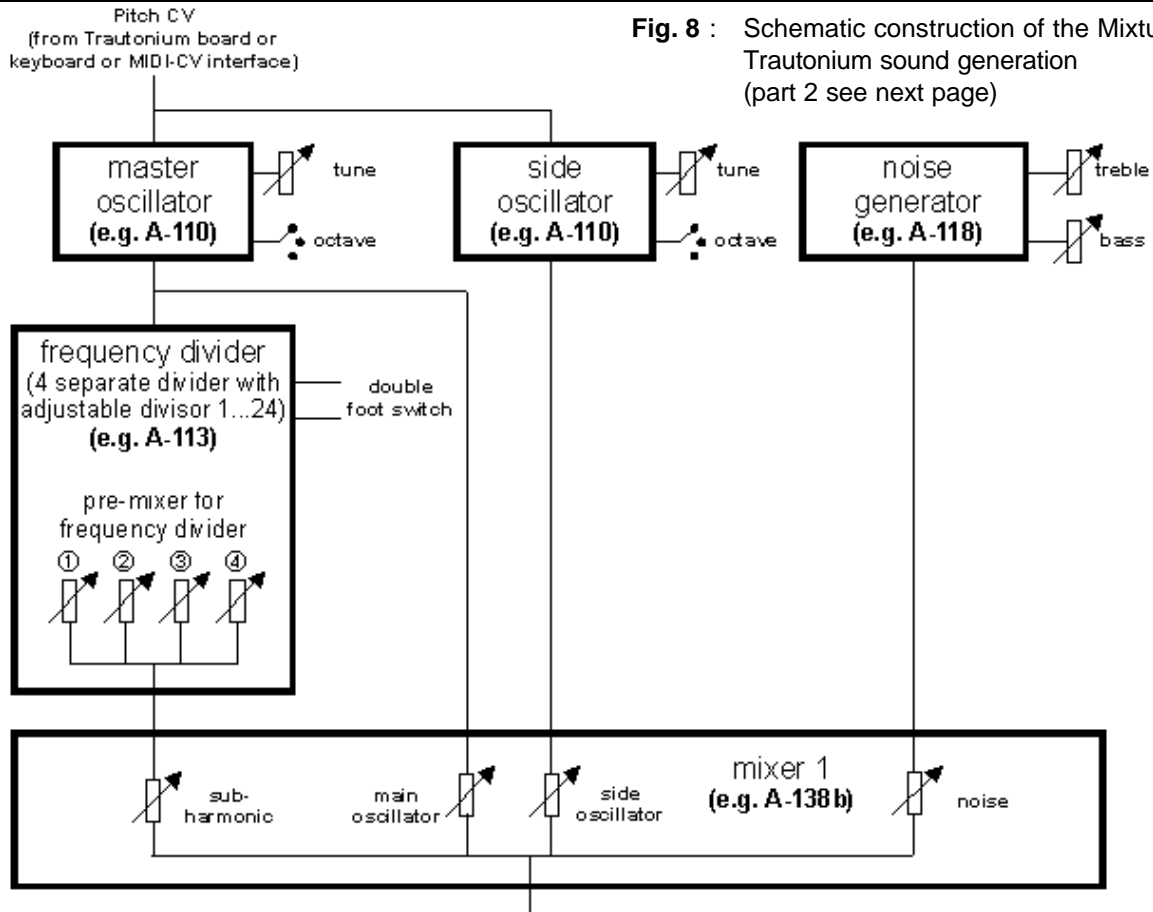
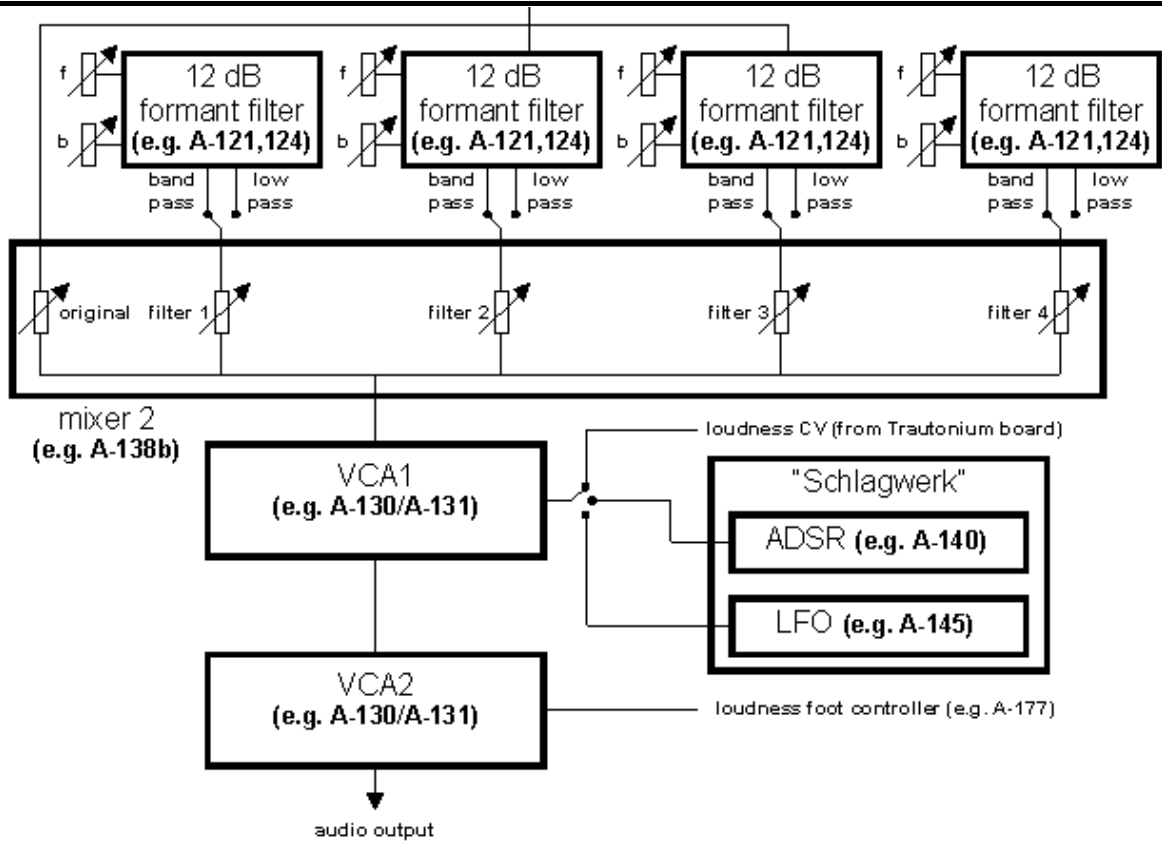



Fig. 8 : Schematic construction of the Mixtur-Trautonium sound generation (part 2 see next page)



 = rotary control
  = rotary switch (can be realized e.g. with patchcords)

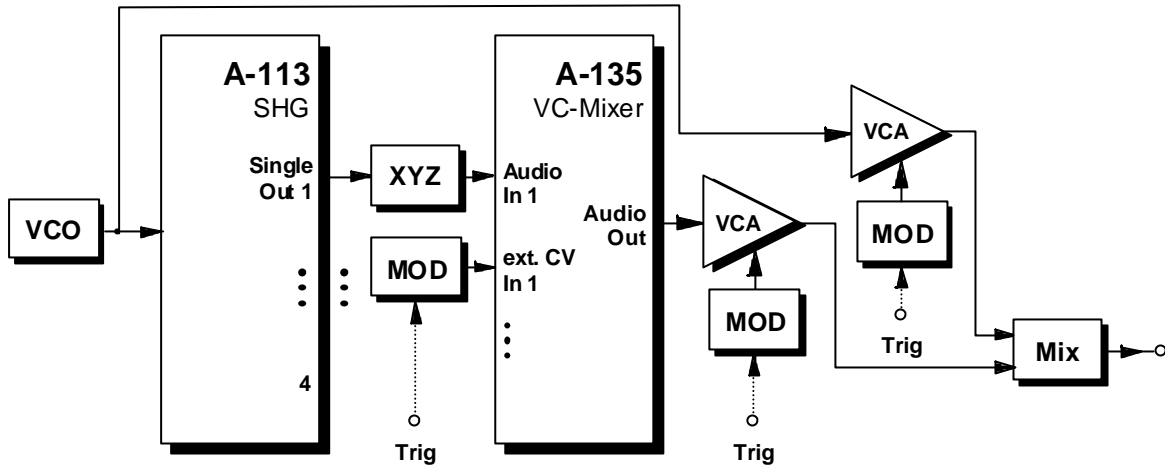

Fig. 9: A-113 as a complex sound source

7. Patch-Sheet

The following diagrams of the module can help you recall your own **Patches**. They're designed so that a complete 19" rack of modules will fit onto an A4 sheet of paper.

Photocopy this page, and cut out the pictures of this and your other modules. You can then stick them onto another piece of paper, and create a diagram of your own system.

Make multiple copies of your composite diagram, and use them for remembering good patches and set-ups.

- P
- Draw in patchleads with colored pens.
 - Draw or write control settings in the little white circles.

